

Diaphragm Valve

LOW PRESSURE MANUAL DIAPHRAGM VALVE

FORGED BODY TYPE

VALVE

PAGE

1 / 2



FEATURES

- Forged body using round bar stock
- Low internal volume
- Minimal particle generation
- Minimal contributions of Moisture, Oxygen and Hydrocarbon
- Permanently heat code laser marked; material traceable to original mill certificate of test
- Hastelloy® C-22™ and custom configurations available upon request

MAJOR SPECIFICATIONS

Size	1/4"	3/8", 1/2"	3/4"
Cv Value	0.3	0.7	0.7
Orifice Size	4.5mm	6.5mm	6.5mm
Max. Working Pressure (G.)	1MPa		
Max. Working Temp.	PCTFE : -10°C ~ 80°C / PI, PFA : -10°C ~ 150°C		
Internal Leakage Allowance (He)	1x10 ⁻¹⁰ Pa · m ³ /s		
Test Pressure ≤ 1×10 ⁻² Torr			
Holding Time ≥ 30 sec.			
External Leakage Allowance (He)	1x10 ⁻¹⁰ Pa · m ³ /s		
Test Pressure ≤ 1×10 ⁻² Torr			
Holding Time ≥ 1 min.			
Particle Inspection (EP only)	No count		
Pressure : 60~80psi N ₂ Gas			
Sample Volume : 1CFM			
0.1µm and Larger			

PRODUCT GRADE

GRADE	AP	BA	EP
Inner Surface Roughness	Ry ≤ 25µm Cut off Length : 2.5mm Measuring Length : 12.5mm	Ry ≤ 3.0µm 10 µinch Ra(Avg.) Cut off Length : 0.8mm Measuring Length : 4mm	Ry ≤ 0.7µm 5 µinch Ra(Avg.) Cut off Length : 0.25mm Measuring Length : 1.25mm
Polishing	Machining Finish	Machining Finish	Electro Polishing Finish

Diaphragm Valve

LOW PRESSURE MANUAL DIAPHRAGM VALVE

FORGED BODY TYPE

VALVE

PAGE

2 / 2

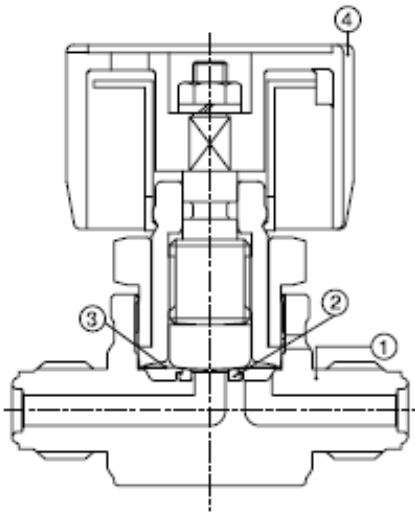

MATERIAL

NO.	NAME	MATERIAL
1	Body	316L Stainless Steel 316L Stainless Steel VAR 304 Stainless Steel
2	Seat	PCTFE / PI / PFA
3	Diaphragm	Ni-Co Alloy
4	Handle	ABS

ORDERING INFORMATION

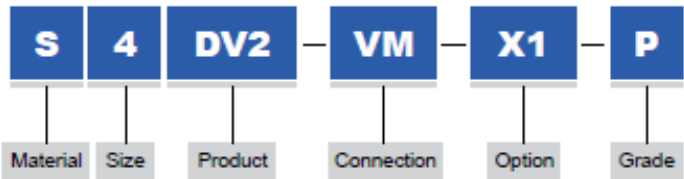

MATERIAL	SIZE	CONNECTION	GRADE
S 316L Stainless Steel	4 1/4"	VM MFS Male	AP AP Grade
D 316L Stainless Steel VAR	6 3/8"	VF MFS Female	BLANK BA Grade
4S 304 Stainless Steel	8 1/2"	SW Lok	P EP Grade
	12 3/4"	TW Butt Weld	

MODEL	CONNECTION	SIZE	A	B	C	D	E	G	H
	MFS Male	1/4"	58	11	66	17	45	28	
		3/8"	76	16	77	28	45	38	
		1/2"	76	16	77	28	45	38	
		3/4"	122	22	85	28	45	38	
	MFS Female	1/4"	78	11	66	17	45	28	
		3/8"	104.6	16	77	28	45	38	
		1/2"	104.6	16	77	28	45	38	
		3/4"	122	22	85	28	45	38	
	Lok	1/4"	69.3	11	66	17	45	28	55
		3/8"	82.5	16	77	28	45	38	68
		1/2"	90.2	16	77	28	45	38	70
		3/4"	106	22	85	28	45	38	84
	Butt Weld	1/4"	135	11	66	17	45	28	
		3/8"	147	16	77	28	45	38	
		1/2"	147	16	77	28	45	38	
		3/4"	150	22	85	28	45	38	