

NM & NL Series

NM & NL Series Metering Valves

Introduction

The Parker NM and NL Series of metering valves provide higher flow rates than the NS Series of metering valves and retain most of the features found in the NS Series.

Features

- Precisely tapered valve stem accurately controls flow
- Brass or 316 SS forged body construction
- Panel or in-line mounting
- Angle or in-line patterns
- Valve stem threads not in contact with process fluid
- 100% function tested
- Optional stem seals and handles

Specifications

- Pressure Rating at all temperatures:
1000 psig (69 bar) CWP

NM Specifications

- Flow Data:
Orifice: 0.06" (1.5mm)
In-line pattern: $C_v = 0.055$; $X_T = 0.41$
Angle pattern: $C_v = 0.057$; $X_T = 0.38$
- Stem Taper: 3°
- Turns to open: 9 +/- 1

NL Specifications

- Flow Data:
Orifice: 0.13" (3.3mm)
In-line pattern: $C_v = 0.207$; $X_T = 0.71$
Angle pattern: $C_v = 0.299$; $X_T = 0.60$
- Stem Taper: 5°
- Turns to open: 10 +/- 1

NM & NL Materials of Construction

Item #	Description	Stainless Steel	Brass
1	Body	ASTM A 182 Type F316	ASTM B 283 Alloy C37700 (Nickel Plated)
2	Bonnet	ASTM A 479 Type 316	ASTM B 16 Alloy C36000 (Nickel Plated)
3	Stem	ASTM A 276 Type 316	ASTM A 276 Type 316
4	Handle*	Stainless Steel	Stainless Steel
5	Panel Nut	ASTM B 16 (Nickel Plated)	ASTM B 16 (Nickel Plated)
6	Sealing Ring	PTFE	PTFE
7	Stem Seal*	Fluorocarbon Rubber	Fluorocarbon Rubber
8	Handle Set Screw**	Stainless Steel	Stainless Steel
9	Handle Lock Screw**	Stainless Steel	Stainless Steel

* Optional Handles and Stem Seal materials are available • See How to Order
** K, and KS Handles use 18-8 stainless steel screws;
V Handles use alloy steel screws; Lock Screws are not used on V Handles
Lubrication: Perfluorinated polyether

Valve / Seal Temperature Ratings

Buna-N Rubber:
-50 °F to 300 °F (-46 °C to 149 °C)

Ethylene Propylene Rubber:
-50 °F to 300 °F (-46 °C to 149 °C)

Neoprene Rubber:
-50 °F to 300 °F (-46 °C to 149 °C)

Fluorocarbon Rubber:
-25 °F to 400 °F (-32 °C to 204 °C)

Highly Fluorinated Fluorocarbon Rubber:
-25 °F to 200 °F (-32 °C to 93 °C)

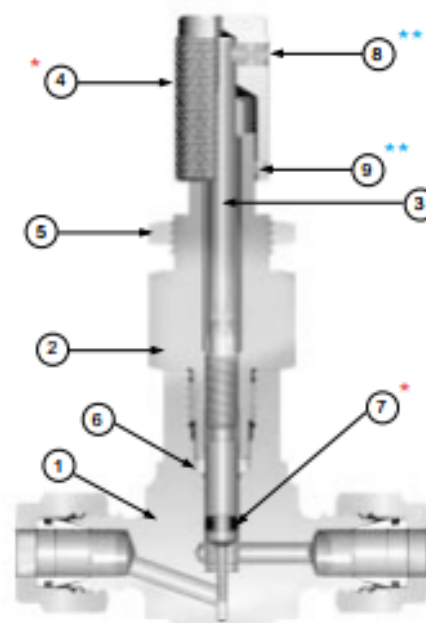

Model Shown: 4A-NML-KZ-SS-K

Note: These products are not intended for use as shut-off valves. For metering valves with shut-off capabilities, please refer to Catalog 4170-HR.

Flow tested in accordance with ISA S75.02. Gas flow will be choked when $P_1 \cdot P_2 / P_1 = x_T$.

Metering Valve

NM & NL Series

NM Series Metering Valves

NM Dimensions

Basic Part Number	End Connections		Dimensions							
	(Inlet) Part 1	(Outlet) Part 2	A†		B†		C		D	
			Inch	mm	Inch	mm	Inch	mm	Inch	mm
2A-NML 2A-NMA	1/8" Compression A-LOK®		1.03	26.2	1.03	26.2	0.41	10.4	1.56	39.6
1.03			26.2	1.03	26.2	0.41	10.4	1.07	27.2	
2F-NML 2F-NMA	1/8" Female NPT		0.93	23.6	0.93	23.6	0.41	10.4	1.56	39.6
0.93			23.6	0.93	23.6	0.41	10.4	1.07	27.2	
2Z-NML 2Z-NMA	1/8" Compression CPI†		1.03	26.2	1.03	26.2	0.41	10.4	1.56	39.6
1.03			26.2	1.03	26.2	0.41	10.4	1.07	27.2	
4A-NML 4A-NMA	1/4" Compression A-LOK®		1.11	28.2	1.11	28.2	0.41	10.4	1.56	39.6
1.11			28.2	1.11	28.2	0.41	10.4	1.07	27.2	
4M-NML 4M-NMA	1/4" Male NPT		0.93	23.6	0.93	23.6	0.41	10.4	1.56	39.6
0.93			23.6	0.93	23.6	0.41	10.4	1.07	27.2	
4V-NML	1/4" VacuSeal		1.03	26.2	1.03	26.2	0.53	13.5	1.56	39.6
4Z-NML 4Z-NMA	1/4" Compression CPI†		1.11	28.2	1.11	28.2	0.41	10.4	1.56	39.6
1.11			28.2	1.11	28.2	0.41	10.4	1.07	27.2	
M3A-NML M3A-NMA	3mm Compression A-LOK®		1.00	25.4	1.00	25.4	0.41	10.4	1.56	39.6
1.00			25.4	1.00	25.4	0.41	10.4	1.07	27.2	
M3Z-NML M3Z-NMA	3mm Compression CPI†		1.00	25.4	1.00	25.4	0.41	10.4	1.56	39.6
1.00			25.4	1.00	25.4	0.41	10.4	1.07	27.2	
M6A-NML M6A-NMA	6mm Compression A-LOK®		1.09	27.7	1.09	27.7	0.41	10.4	1.56	39.6
1.09			27.7	1.09	27.7	0.41	10.4	1.07	27.2	
M6Z-NML M6Z-NMA	6mm Compression CPI†		1.09	27.7	1.09	27.7	0.41	10.4	1.56	39.6
1.09			27.7	1.09	27.7	0.41	10.4	1.07	27.2	

Note:

For K & KS Handles on in-line pattern valves:

E = 3.22 (81.8mm), F = 2.99 (75.9mm), G = 0.50 (12.7mm), H = 0.58 (14.7mm), I = 0.19 (4.8mm)

For K & KS Handles on angle pattern valves:

E = 2.82 (71.6mm), F = 2.59 (65.8mm), G = 0.50 (12.7mm), H = 0.58 (14.7mm), I = 0.27 (6.9mm)

For V Handles on in-line pattern valves:

E = 3.63 (92.2mm), F = 3.40 (86.4mm), G = 0.84 (21.3mm), H = 0.58 (14.7mm), I = 0.19 (4.8mm)

For V Handles on angle pattern valves:

E = 3.23 (82.0mm), F = 3.00 (76.2mm), G = 0.84 (21.3mm), H = 0.58 (14.7mm), I = 0.27 (6.9mm)

† For CPI® and A-LOK®, dimensions are measured with nuts in the finger tight position.

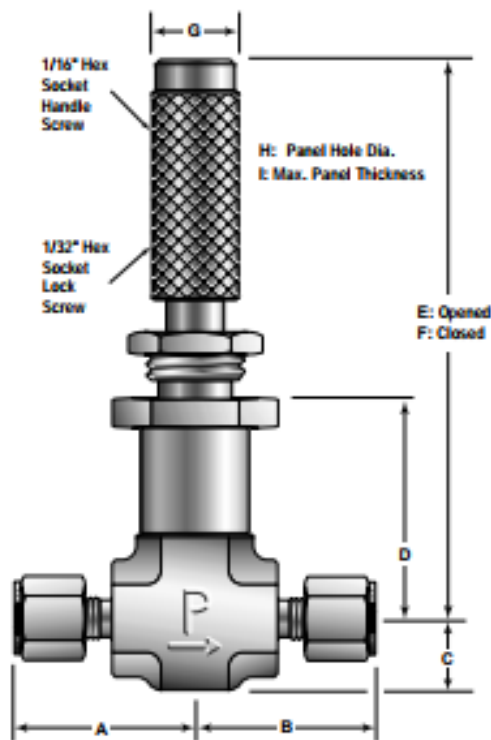

Model Shown: M3A-NML-V-SS-K

NM Series - C_v vs. Turns Open

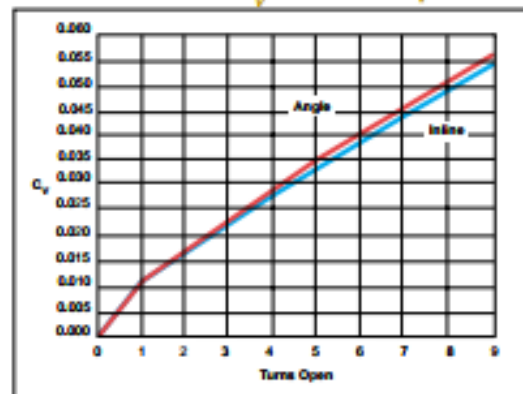

NM Series - Water Flow Data

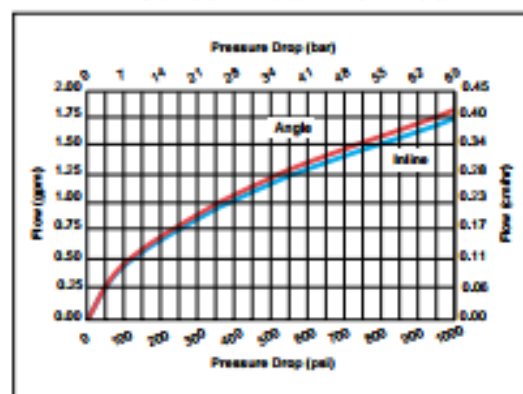

Metering Valve

NM & NL Series

NL Series Metering Valves

NL Dimensions

Basic Part Number	End Connections		Dimensions							
	(Inlet) Port 1	(Outlet) Port 2	A†		B†		C		D	
			Inch	mm	Inch	mm	Inch	mm	Inch	mm
2F-NLL 2F-NLA	1/8" Female NPT		0.93	23.6	0.93	23.6	0.41	10.4	1.56	39.6
4A-NLL 4A-NLA	1/4" Compression A-LOK*		1.16	29.5	1.16	29.5	0.41	10.4	1.56	39.6
4M-NLL 4M-NLA	1/4" Male NPT		0.93	23.6	0.93	23.6	0.41	10.4	1.56	39.6
4V-NLL	1/4" VacuSeal		1.03	26.2	1.03	26.2	0.53	13.5	1.56	39.6
4Z-NLL 4Z-NLA	1/4" Compression CPI*		1.16	29.5	1.16	29.5	0.41	10.4	1.56	39.6
6A-NLL	3/8" Compression A-LOK*		1.24	31.5	1.24	31.5	0.41	10.4	1.56	39.6
6Z-NLL	3/8" Compression CPI*		1.24	31.5	1.24	31.5	0.41	10.4	1.56	39.6
M6A-NLL M6A-NLA	6mm Compression A-LOK*		1.12	28.4	1.12	28.4	0.41	10.4	1.56	39.6
M6Z-NLL M6Z-NLA	6mm Compression CPI*		1.12	28.4	1.12	28.4	0.41	10.4	1.56	39.6

† For CPI* and A-LOK*, dimensions are measured with nuts in the finger tight position.

Note:

For K & KS Handles on in-line pattern valves:

E = 2.92 (74.2mm), F = 2.67 (67.8mm),
G = 0.50 (12.7mm), H = 0.58 (14.7mm),
I = 0.19 (4.8mm)

For K & KS Handles on angle pattern valves:

E = 2.83 (71.9mm), F = 2.58 (65.8mm),
G = 0.50 (12.7mm), H = 0.58 (14.7mm),
I = 0.27 (6.9mm)

For V Handles on in-line pattern valves:

E = 3.33 (84.6mm), F = 3.08 (78.2mm),
G = 0.84 (21.3mm), H = 0.58 (14.7mm),
I = 0.19 (4.8mm)

For V Handles on angle pattern valves:

E = 3.24 (82.3mm), F = 2.99 (75.9mm),
G = 0.84 (21.3mm), H = 0.58 (14.7mm),
I = 0.27 (6.9mm)

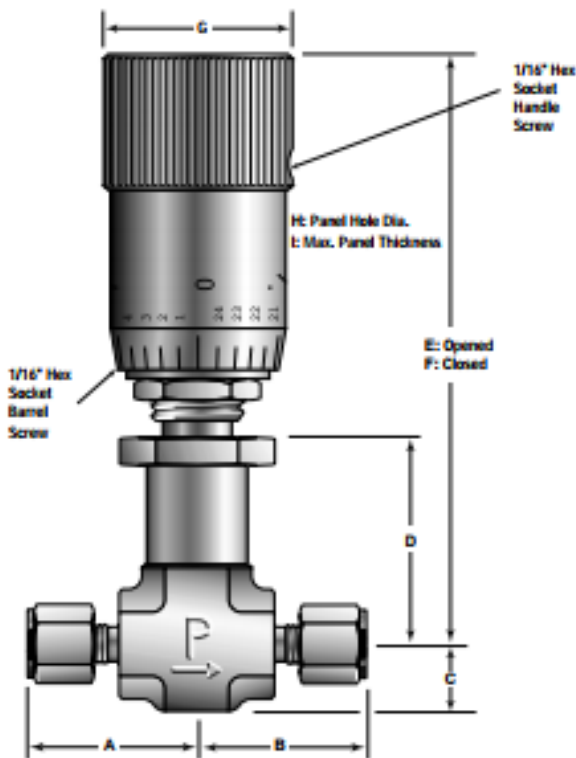

Model Shown: 6A-NLL-EPR-B-V

NL Series - C_v vs. Turns Open

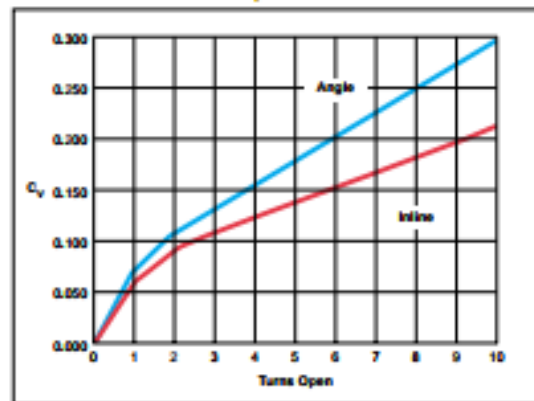

NL Series - Water Flow Data

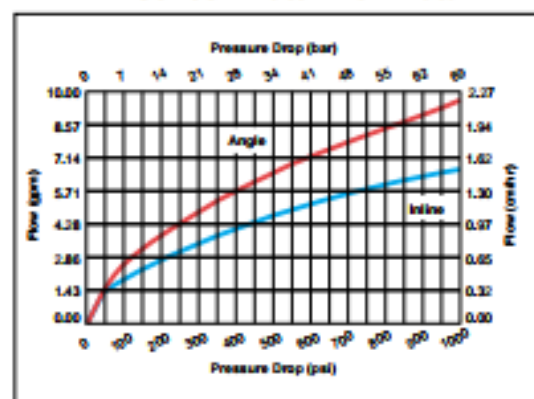

Metering Valve

NM & NL Series

N Series Metering Valves

How to Order

The correct part number is easily derived from the following number sequence. The six product characteristics required are coded as shown below. *Note: If the inlet and outlet ports are the same, eliminate the outlet port designator.

Example: 4Z - NLL - V - SS - V

 ① ② ③ ④ ⑤ ⑥

 Inlet Outlet Valve Seal Body Handle

 Port Port Series Material Material Type

① Inlet Port	② Outlet Port	③ Valve Series	④ Seal Material	⑤ Body Material	⑥ Handle Type
1A, 1Z, 2A, 2M, 2Z, 4A, 4V, 4Z, M3A, M3Z, M6A, M6Z		NSA NSL	BN - Buna-N Rubber EPR - Ethylene Propylene Rubber NE - Neoprene Rubber V - Fluorocarbon Rubber KZ - Highly Fluorinated Fluorocarbon Rubber	SS- Stainless Steel B - Brass	K - Knurled
2A, 2F, 2Z, 4A, 4M, 4V, 4Z, M3A, M3Z, M6A, M6Z		NMA NML			KS - Knurled with Slot
2F, 4A, 4M, 4V, 4Z, 6A, 6Z, M6A, M6Z		NLA NLL			V - Vernier F - Precision Adjustment*

* F Handle available only on NS Series.

Optional Handles

Knurled (K) and
Knurled with Slot (KS)

Vernier (V)

Precision Adjustment (F)



- Knurled K Handle for ease of actuation
- Knurled with Slot (KS) adds a screw-driver slot across the top for locations where handle access is difficult



- Precision graduated aluminum alloy permits repeatable flow settings
- Resolution to 1/25th turn



- Adjustable torque handle for precise positioning
- Knurled metal with two top mounted adjustment screws
- NS Series only

How to Order Options

Oxygen Cleaning – Add the suffix **-C3** to the end of the part number to receive valves cleaned and assembled for oxygen service in accordance with Parker Specification ES8003. **Example:** 4A-NMA-EPR-SS-V-C3